

Product information presented here reflects conditions at time of publication. Consult factory regarding discrepancies or inconsistencies.



# TECHNICAL DATA SHEET

## WASTE-MATE SERIES

Models X404, X405 Submersible Sewage Pumps For Hazardous Location  
 Class I, Division 1, Groups C & D Rated  
 Class I, Zone 1, Groups IIA & IIB

### PRODUCT SPECIFICATIONS

### SINGLE SEAL

<b>MOTOR</b>	Horse Power	2 (X404) or 3 (X405)
	Voltage	200 - 575
	Phase	1 or 3 Ph
	Hertz	60 Hz
	RPM	1750
	Type	Permanent split capacitor or 3 Ph
	Insulation	Class B
	Amps	4.1 - 20.2
<b>PUMP</b>	Operation	Nonautomatic
	Discharge Size	4" horizontal
	Solids Handling	3" (76 mm) spherical solids
	Cord Length	20' (6 m) standard
	Cord Type	UL listed 5-wire (1 Ph) or 8-wire (3 Ph) SOOW
	Max. Head	38' (11.6 m)
	Max. Flow Rate	361 GPM (1367 LPM)
	Max. Operating Temp.	104 °F (40 °C)
	Cooling	Oil filled
	Motor Protection	Auto reset thermal overload (1 Ph) or thermal sensor (3 Ph)
	<b>MATERIALS</b>	Upper Bearing
Lower Bearing		Ball bearing
Mechanical Seals		Carbon and ceramic with stainless steel parts
Impeller Type		Non-clogging vortex
Impeller		Cast iron
Hardware		Stainless steel
Motor Shaft		416 stainless steel
Gasket		Neoprene square ring and gasket

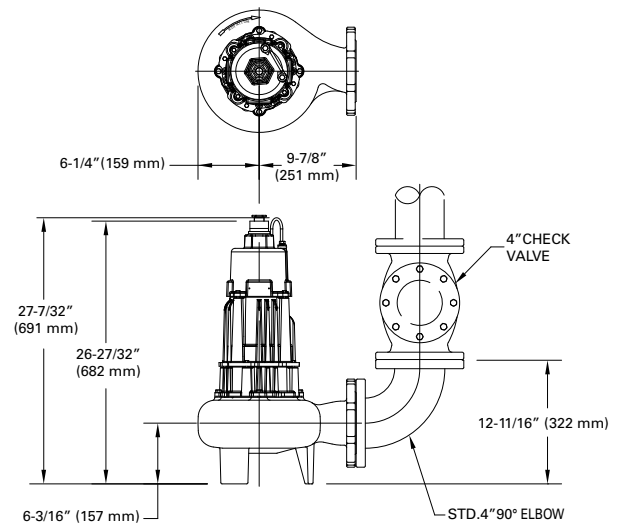

SK1915

All Class 30 cast iron construction.

NOTE: The sizing of effluent systems normally requires variable level float(s) controls and properly sized basins to achieve required pumping cycles or dosing timers with nonautomatic pumps.

NOTE: See model comparison chart for specific details.



# TOTAL DYNAMIC HEAD FLOW PER MINUTE

MODEL		X404		X405	
Feet	Meters	Gal.	Liters	Gal.	Liters
5	1.5	300	1136	361	1367
10	3.0	265	1003	326	1234
15	4.6	224	848	284	1075
20	6.1	184	698	241	912
25	7.6	134	503	197	746
30	9.1	60	227	134	507
35	10.7	--	--	50	189
Shut-off Head:		33 ft.(10.1m)		38 ft.(11.6m)	

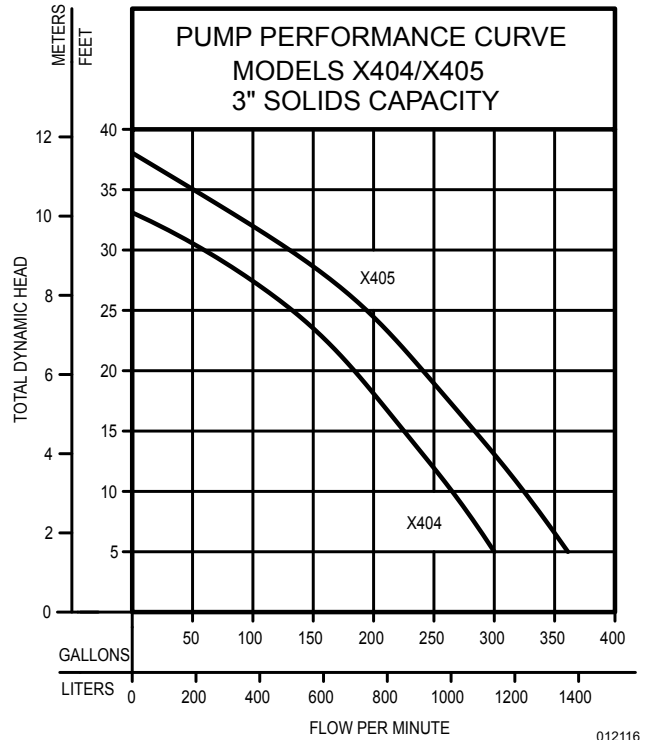

Model	MODEL COMPARISON										
	Seal	Mode	Volts	Ph	Amps	HP	Hz	Lbs	Kg	Simplex	Duplex
EX404	Single	Non	230	1	12.9	2	60	175	79	1 & 2	1 & 2
IX404	Single	Non	200	1	14.4	2	60	175	79	1 & 2	1 & 2
JX404	Single	Non	200	3	13.8	2	60	175	79	1 & 2	1 & 2
FX404	Single	Non	230	3	10.5	2	60	175	79	1 & 2	1 & 2
GX404	Single	Non	460	3	5.2	2	60	175	79	1 & 2	1 & 2
BAX404	Single	Non	575	3	4.1	2	60	175	79	1 & 2	1 & 2
EX405	Single	Non	230	1	19.0	3	60	175	79	1 & 2	1 & 2
IX405	Single	Non	200	1	20.2	3	60	175	79	1 & 2	1 & 2
JX405	Single	Non	200	3	14.8	3	60	175	79	1 & 2	1 & 2
FX405	Single	Non	230	3	12.2	3	60	175	79	1 & 2	1 & 2
GX405	Single	Non	460	3	6.1	3	60	175	79	1 & 2	1 & 2
BAX405	Single	Non	575	3	4.8	3	60	175	79	1 & 2	1 & 2

Additional cord lengths are available in 35' (11 m) and 50' (15 m).

All Models are, cCSAus approved

Tested to FM Standards 3600 & 3615 by CSA

## SELECTION GUIDE

1. See FM1705 for correct intrinsically-safe simplex or duplex panel.
2. See FM0526 for variable level control switches rated 30VDC are used as a control activator. Quantity required dependent upon panel selection.

**CAUTION** All installation of controls, protection devices and wiring should be done by a qualified licensed electrician. All electrical and safety codes should be followed including the most recent National Electrical Code (NEC) and the Occupational Safety and Health Act (OSHA).